

CF1231A Instruction Manual

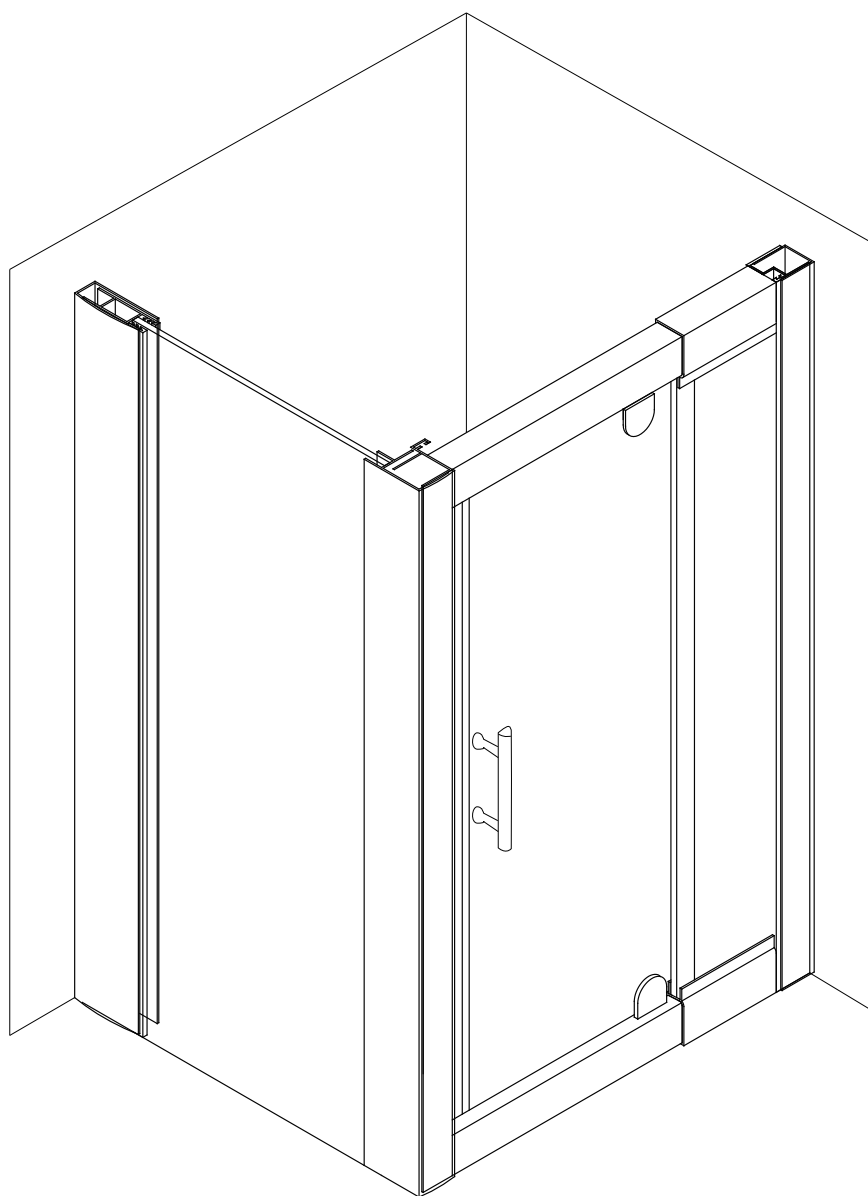

◆ General Information

Please inspect the product immediately upon receipt for transit damage, missing packs/parts or manufacturing fault. Damage reported later cannot be accepted. Please handle the product with care avoiding knocks and shock loading to all sides and edges of the glass.

Notes: Safety glass can not be re-worked.

Please read these instructions carefully before start of installation.

Special care should be taken when drilling walls to avoid hidden pipes or electrical cables.

Note: This product is heavy and may require two people to install.

Aftercare instructions

After use, your shower should be cleaned with soap and water. This is particularly important in hard water districts where insoluble lime salts may be deposited and allowed to build up.

Cleaners of a gritty or abrasive nature should not be used. Care should be taken to avoid contact with strong chemicals such as organic solvents and strippers.

Glass cleaners can be used but with caution, if in doubt contact the manufacturer of the cleaner in question.

Please keep these instructions for aftercare and customer service details.

Tools Required

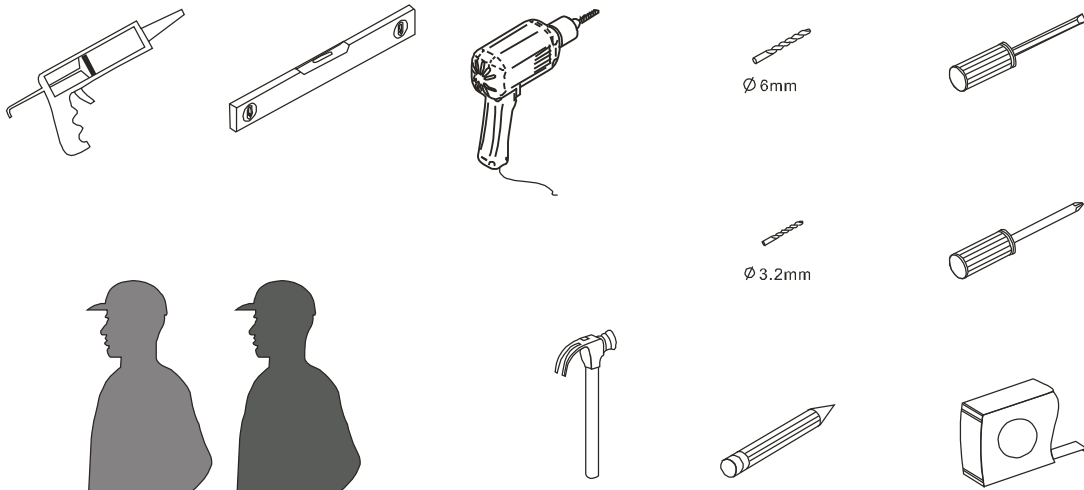

This product is heavy and may require two people to install.



◆ Assembly Drawing

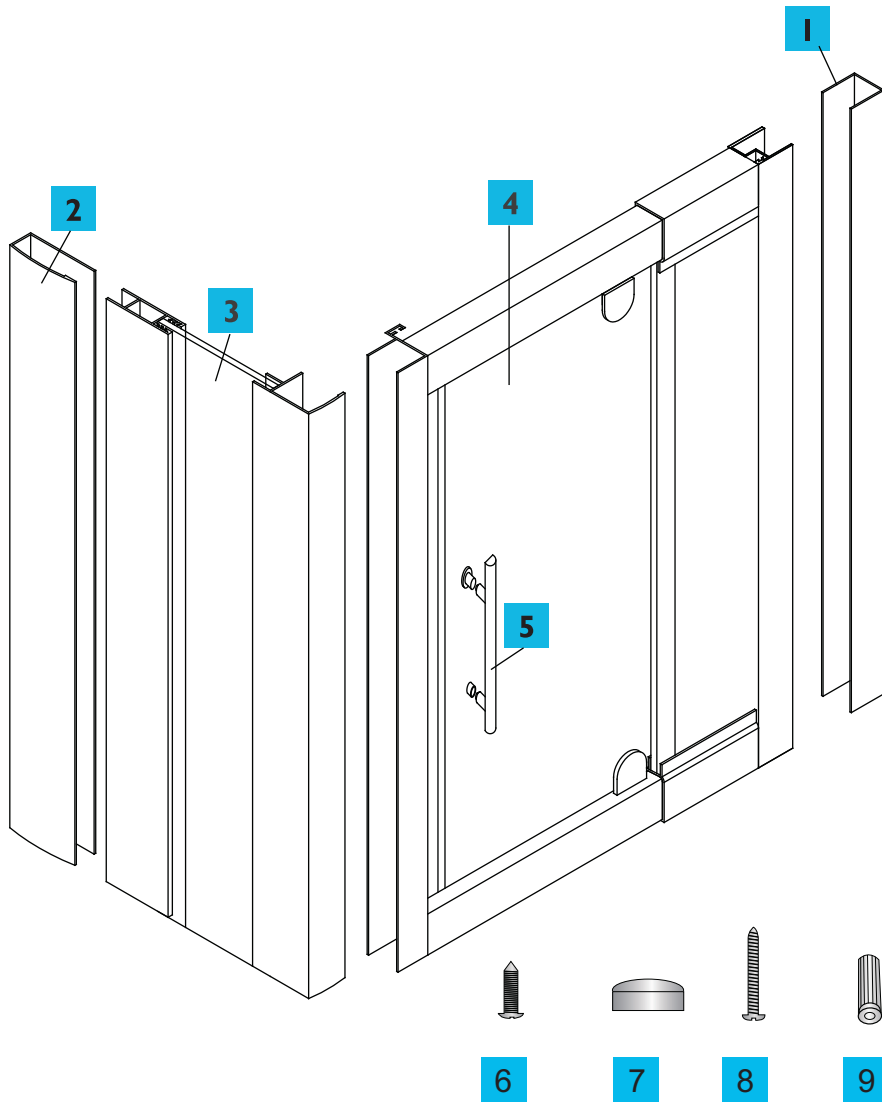

REQUIRED PARTS

- | | | | |
|---|------------------------------|---|------------------------------------|
| 1 | 1 x Door front assembly jamb | 2 | 1 x Fixed panel wall jamb |
| 3 | 1 x Fixed side panel | 4 | 1 x Door front assembly |
| 5 | 1 x Handle set | 6 | 15 x Fixed panel screws - 8mm |
| 7 | 8 x Fixed panel screw caps | 8 | 8 x Wall jamb fixing screws - 35mm |
| 9 | 8 x 6mm wall plugs | | |

◆ Installation Steps

Step 1

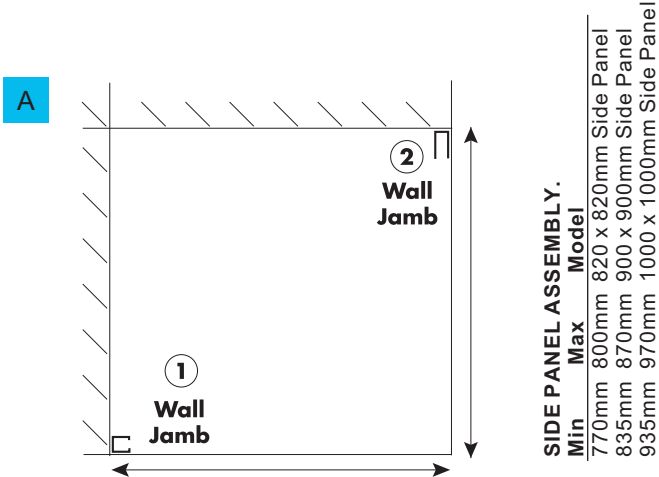

A

Measure your shower base / shower area. The measurement to the outside edge of the wall jambs (1 & 2) should be somewhere within the minimum and maximum of the screen size. See chart to the left.

Note: If using the maximum size make sure that you allow for walls that may be out of plumb. If your walls are 10mm out of plumb reduce your screen size area by this amount.

FRONT PANEL ASSEMBLY.

Min	Max	Model
750mm	810mm	820 x 820mm Front set
830mm	890mm	900 x 900mm Front set
930mm	990mm	1000 x 1000mm Front set
1140mm	1200mm	1200 Front set

Step 2

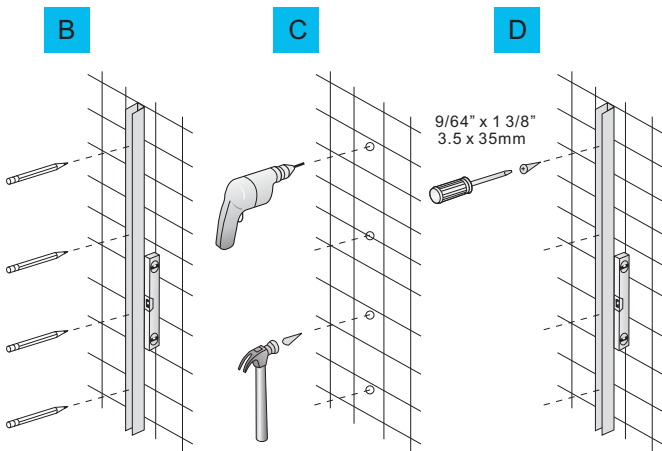

B

Using a level ensure jambs (1&2) are plumb then mark the outside edge with a pencil. Then mark your predrilled screw holes that are on the inside of the jamb.

C

Remove jambs and drill 6mm holes with drill bit. Insert plastic wall plugs (9) that are provided.

Note: Please use the correct or most suitable fixing for the surface you are screwing into, to ensure the jamb is securely fixed to the wall eg. toggle wall plug.

D

Using a level, ensure jambs (1 & 2) are plumb and the holes in the jamb line up with the holes in the wall. Fix jamb to wall using the screws provided (8).

Step 3

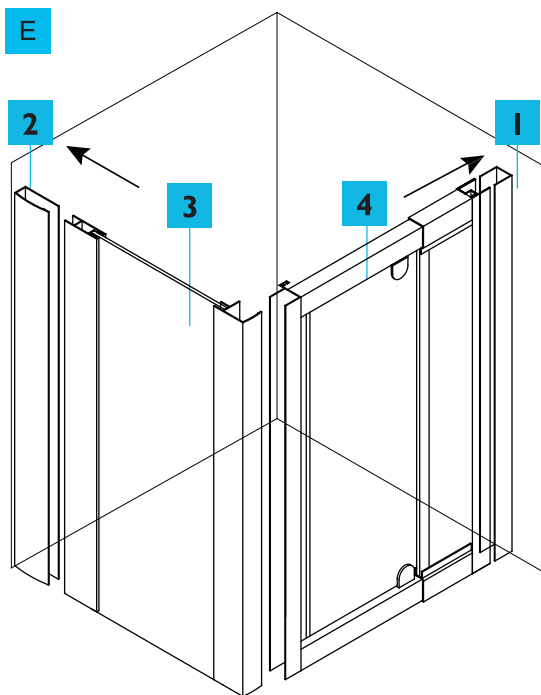

- E** Slide fixed panel (3) and door front assembly (4) into jambs (1 & 2)
Hint: Insert top or bottom corner first then you will find that the rest of the panel will slide in easily.

Step 4

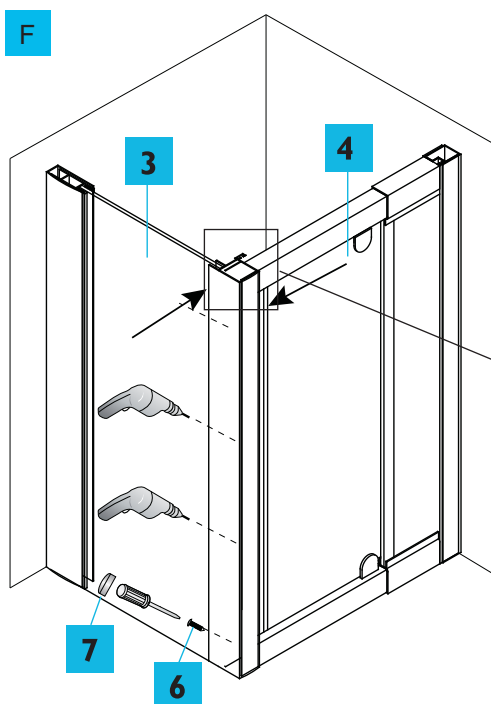

- F** Slide front of fixed panel (3) over extrusion on front door assembly (4). Now drill 4 equally spaced 3.2mm holes on the **INSIDE** of the screen (See aerial view). Fix side panel (3) to front assembly (4) using fixed panel screws 8mm (6). Cap all screws using fixed panel screw caps (7).

Aerial View

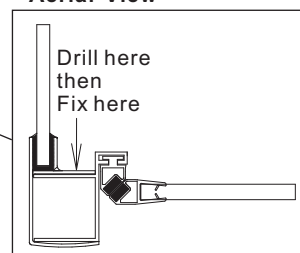

Step 5

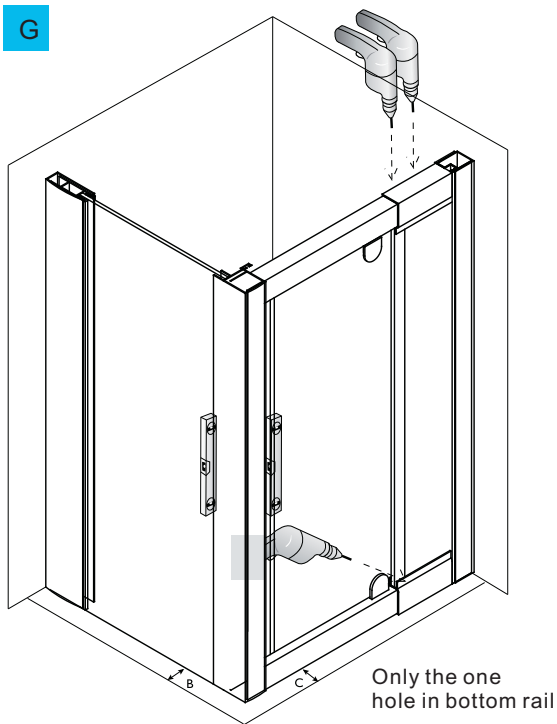

G Adjust front assembly and fixed side panel so $B=C$. This is done by sliding the fixed panel in or out of the wall extrusion for the fixed side. For the front, the top and bottom rails of the front assembly slide apart for adjustment. Now fix off the bottom rail at the location pictured on the inside of the screen. Using a level ensure front assembly and side panel are vertical. Now drill 3.2mm holes then fix with screws (6) as shown to top rail of front assembly.

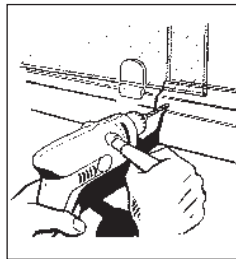

INSIDE SHOWER VIEW

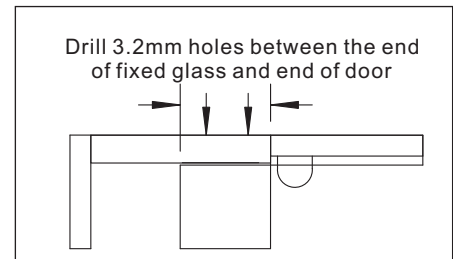

FRONT SHOWER VIEW

Step 6

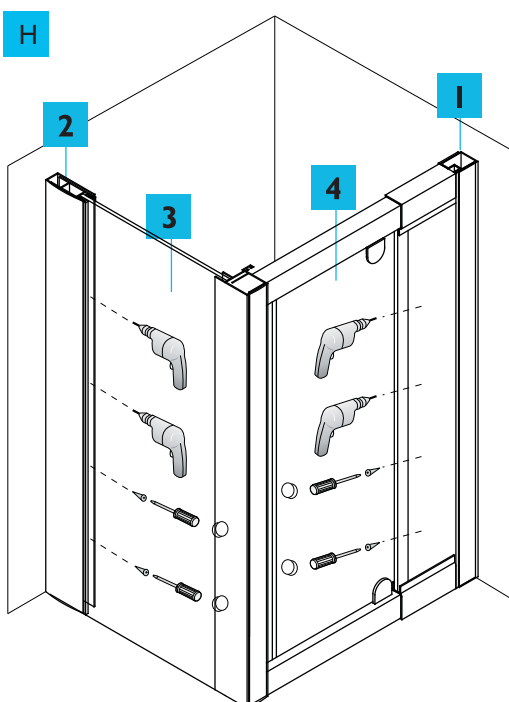

H Now drill 4 equally spaced 3.2mm holes into the wall jambs (1 & 2) on the **INSIDE** of the screen. Make sure that your drill holes are more than 20mm back from the glass edge, when using smallest screen size, otherwise you may break the glass. Make sure that the holes also go through the aluminium of the fixed side panel and the door front assembly. Fix off wall jambs (1 & 2) to fixed side panels (3 & 4) using fixed panels screws (6) and covering them with caps (7) provided

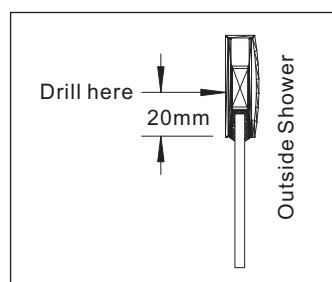

Step 7

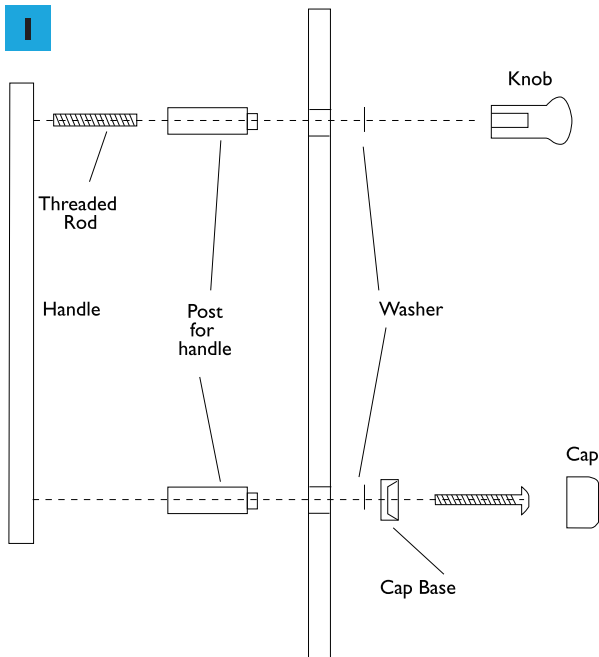

I Attach handle to the door as shown.

Step 1 Screw the threaded rod into the handle.

Step 2 Slide top post onto the threaded rod, making sure the post is facing the right way

Step 3 Put standard screw into cap base then into washer then into the lower hole in the glass. On the other side of the glass slide the lower post onto the standard screw, making sure the post faces the right way

Step 4 Bring the handle up to the glass, allowing the top post to locate into the hole in the glass. Fix the knob onto the threaded rod, making sure the washer is between the glass and the knob.

Step 5 Line up the hole in the handle with the standard screw and post assembly. Screw tightly together.

Step 6 Place cap over cap base.

Step 8

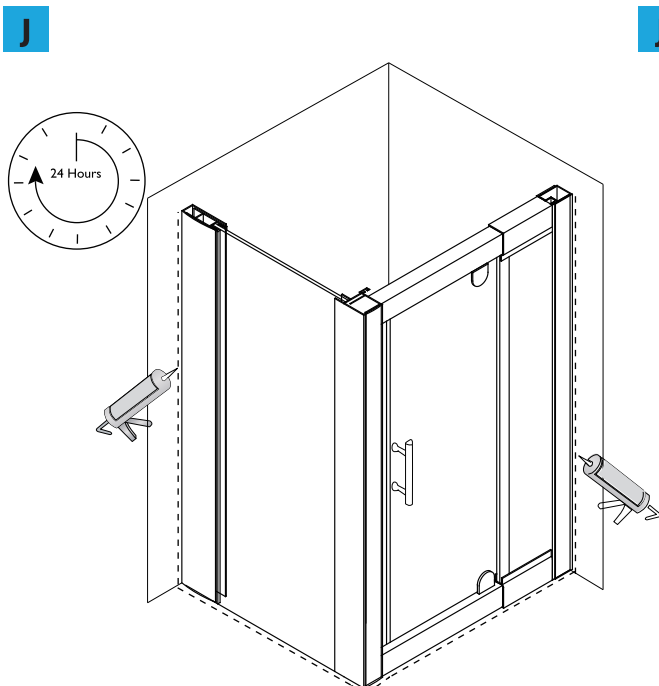

J Apply silicone sealer around all external joints of shower screen and allow 24 hours for silicone to set.

Silicone is not used on the inside of the shower screen because in time water can build up within the wall jamb and make the screen leak out of the shower area. The screens are designed to allow the water to return into the shower area if any is present.

Screens that are sealed on the inside, will void warranty.